



Completely Re-engineered

Twenty-five years of advanced experience in molding, manufacturing, logistics, transportation, materials, application have gone into Hydrosel Canada's **KAPLAN** True Union Ball Valves. This valve is completely designed to address today's fast-paced world and global trade.

True Union Functionality

Incorporating this tried-and-tested functionality, Hydrosel Canada has gone one step further. The **KAPLAN** valve may be retrofitted with spare parts from our unions, flanges and sharkfellow Ball Check Valve.

Features

- Rated at 200 PSI
- Easy 1/4-Turn Operation
- Full Port Design
- True Union Functionality
- Reversible PTFE Seats
- Double O-Ring Stem Assembly
- Breakaway Failsafe Stem Assembly
- Retrofitted with Parts from WTF Flanges.
- Suitable for ASTM, DIN, JIS and CNS systems
- NSF Compliant

Durability

With a combination of nine seals and two sturdy teflon seats, this valve is designed for superior performance. The seats are reversible so damages will not result in costly down-time.

Actuator Ready

Similar to our other valves, **KAPLAN** may easily be converted to automated valves - in the field.

Options

- Socket or Threaded Connectors
- Electric Actuators
- Pneumatic Actuators
- PVC, CPVC, PP and PVDF
- EPDM, Viton or Nitrile O-Rings

SIZE: 1/2" ~ 4"

JOINT END:
SOCKET - ASTM, DIN, JIS
THREAD - NPT, BSPT

WORKING PRESSURE:
200 PSI

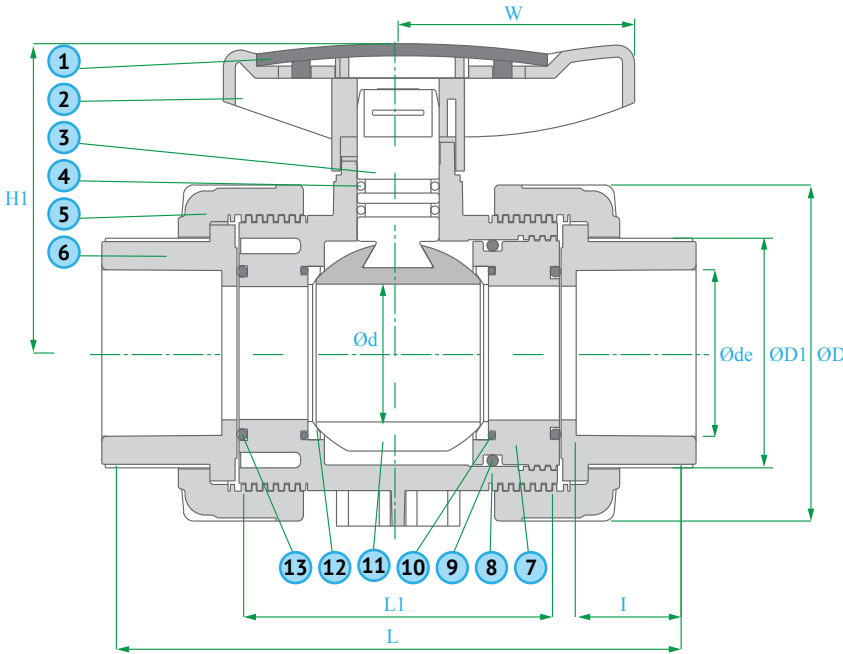

CONSTRUCTION			
NO	PARTS	PCS	MATERIALS
1	HANDLE CAP	1	ABS
2	HANDLE	1	ABS
3	STEM	1	PVC, CPVC, PP
4	O-RING	2	EPDM, VITON
5	NUT	2	PVC, CPVC, PP
6	CONNECTOR	2	PVC, CPVC, PP
7	INSERT	1	PVC, CPVC, PP
8	BODY	1	PVC, CPVC, PP
9	O-RING	1	EPDM, VITON
10	O-RING	2	EPDM, VITON
11	BALL	1	PVC, CPVC, PP
12	SEAT	2	PTFE
13	O-RING	2	EPDM, VITON

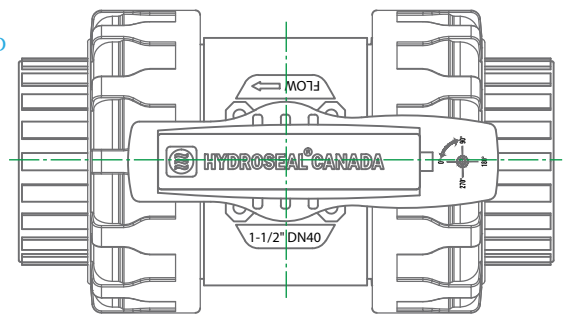

PART	NOMINAL SIZE	SOCKET, THREAD TYPE	UNIT OF MEASURE: MM						ASTM		DIN		JIS		W
			DN	D	D1	d	H1	L	L1	de	l	de	l	de	
KPES.0050	1/2"	DN 15	46.0	32.0	13.0	49.0	116.0	62.0	21.3	22.6	20.0	17.0	22.0	22.6	45.0
KPES.0075	3/4"	DN 20	56.0	38.0	19.0	60.0	133.0	72.0	26.7	25.5	25.0	19.5	26.0	25.5	52.0
KPES.0100	1"	DN 25	66.0	45.0	25.0	69.0	150.0	80.0	33.4	28.6	32.0	23.0	32.0	28.6	58.0
KPES.0125	1 1/4"	DN 32	82.0	55.0	31.0	76.0	168.0	87.0	42.2	31.9	40.0	27.0	38.0	31.9	66.0
KPES.0150	1 1/2"	DN 40	98.0	67.0	40.0	91.0	173.0	94.0	48.3	35.1	50.0	32.0	48.0	35.1	69.0
KPES.0200	2"	DN 50	120.0	81.0	50.0	110.0	206.0	112.0	60.3	38.2	63.0	37.5	60.0	38.2	81.0
KPES.0250	2 1/2"	DN 65	120.0	89.0	50.0	110.0	211.0	112.0	73.0	41.4	75.0	41.5	76.0	41.4	81.0
KPES.0300	3"	DN 80	162.0	108.0	75.0	140.0	262.0	147.0	88.9	48.0	90.0	51.0	89.0	51.0	118.0
KPES.0400	4"	DN 100	220.0	134.0	100.0	185.0	311.0	177.0	114.3	57.5	110.0	61.0	114.0	61.0	140.0

SELECTION CHART				
SIZE	MATERIAL	CONNECTION	SEALS	PRESSURE RATING
1/2" ~ 4"	PVC CPVC PP	SOCKET or THREAD	EPDM or VITON	200 PSI @ 73F Non-Shock

CV FACTORS			
SIZE	FACTOR	SIZE	FACTOR
1/4"	-	1 1/2"	90
3/8"	-	2"	140
1/2"	8	2 1/2"	330
3/4"	15	3"	480
1"	29	4"	600
1 1/4"	75	6"	-

Pressure Loss Calculation Formula

$$\Delta P = \left[\frac{Q}{C_v} \right]^2$$

ΔP = Pressure Drop
 Q = Flow in GPM
 C_v = Flow Coefficient

