

## Caps

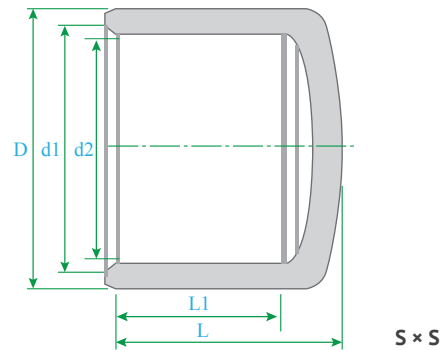

PART	NOMINAL SIZE	CAP - S x S	UNIT OF MEASURE: MM				APPROX. WT.
			D	d1	d2	L1	
0307.CAP.0050	1/2"	30.00	21.54	21.23	23.00	30.00	0.02
0307.CAP.0075	3/4"	35.00	26.87	26.57	26.00	34.00	0.02
0307.CAP.0100	1"	43.00	33.66	33.27	29.00	38.00	0.04
0307.CAP.0125	1 1/4"	53.00	-	-	32.00	32.00	0.07
0307.CAP.0150	1 1/2"	60.00	48.56	48.11	35.00	46.00	0.09
0307.CAP.0200	2"	72.00	60.63	60.17	40.00	52.00	0.12
0307.CAP.0250	2 1/2"	88.00	73.38	72.85	44.50	50.00	0.18
0307.CAP.0300	3"	105.00	89.31	88.70	48.00	66.00	0.26
0307.CAP.0400	4"	134.00	114.76	114.07	57.50	76.00	0.45
0307.CAP.0600	6"	193.00	168.83	168.00	77.00	104.00	1.33
0307.CAP.0800	8"	243.00	219.84	218.70	102.00	158.00	2.40
0307.CAP.1000	10"	313.00	273.81	272.67	140.00	208.00	3.80
0307.CAP.1200	12"	365.00	324.61	323.47	160.00	242.00	7.00

**Notes:** Physical dimensions and tolerances meet the requirements of ASTM Standard D-2467. PVC material meets ASTM Standard D-1784. Dimensions are subject to change without notice. Contact your HYDROSEAL representative for certification.