

PVC SCHEDULE 80 FITTINGS

Weights, Dimensions and Tolerances

SECTION

90° Elbows

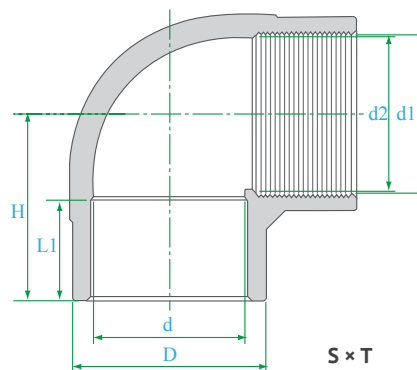
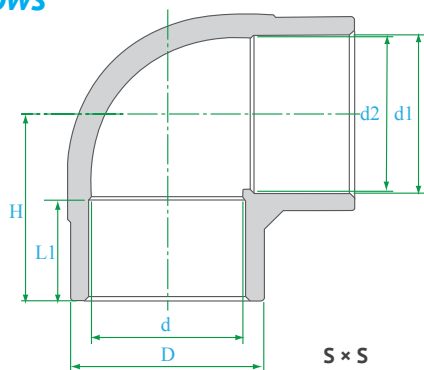

PART	NOMINAL SIZE	90 ELL - S x S	UNIT OF MEASURE: MM					APPROX. WT.
			D	d	d1	d2	L1	
0307.E90.0050	1/2"	29.50	19.00	21.54	21.23	22.50	35.00	0.03
0307.E90.0075	3/4"	35.00	24.00	26.87	26.57	25.50	40.00	0.05
0307.E90.0100	1"	43.00	31.00	33.65	33.27	29.00	47.50	0.08
0307.E90.0125	1 1/4"	52.50	40.00	42.42	42.04	32.00	55.00	0.13
0307.E90.0150	1 1/2"	59.00	46.00	48.56	48.11	35.00	62.00	0.17
0307.E90.0200	2"	72.00	58.00	60.63	60.17	38.50	71.50	0.26
0307.E90.0250	2 1/2"	87.50	70.00	73.38	72.85	44.50	83.50	0.45
0307.E90.0300	3"	105.00	86.00	89.31	88.70	48.00	95.00	0.70
0307.E90.0400	4"	132.00	110.00	114.76	114.07	57.50	117.50	1.17
0307.E90.0500	5"	-	-	-	-	-	-	1.94
0307.E90.0600	6"	193.00	164.00	168.83	168.00	77.00	167.00	3.03
0307.E90.0800	8"	245.00	214.00	219.84	218.70	100.00	224.00	7.80
0307.E90.1000	10"	318.00	-	273.81	272.67	140.00	340.00	13.00
0307.E90.1200	12"	356.00	-	324.61	323.47	160.00	338.00	23.00
0307.E90.1400	14"	399.00	-	356.39	-	178.00	369.00	27.00
0307.E90.1600	16"	450.00	-	407.19	-	204.00	427.00	29.00
0307.E90.1800	18"	505.00	-	457.99	-	228.00	490.00	38.00
0307.E90.2000	20"	563.00	-	517.07	-	254.00	510.00	47.00
0307.E90.2400	24"	674.00	-	611.58	-	305.00	617.00	63.00

PART	NOMINAL SIZE	90 ELL - S x T	UNIT OF MEASURE: MM					APPROX. WT.
			D	d	d1	d2	L1	
0307.FEP.0050	1/2"	29.50	19.00	21.54	21.23	22.50	35.00	0.03
0307.FEP.0075	3/4"	35.00	24.00	26.87	26.57	25.50	40.00	0.05
0307.FEP.0100	1"	43.00	31.00	33.65	33.27	29.00	47.50	0.08
0307.FEP.0125	1 1/4"	52.50	40.00	42.42	42.04	32.00	55.00	0.13
0307.FEP.0150	1 1/2"	59.00	46.00	48.56	48.11	35.00	62.00	0.17
0307.FEP.0200	2"	72.00	58.00	60.63	60.17	38.50	71.50	0.26
0307.FEP.0250	2 1/2"	87.50	70.00	73.38	72.85	44.50	83.50	0.45
0307.FEP.0300	3"	105.00	86.00	89.31	88.70	48.00	95.00	0.70
0307.FEP.0400	4"	132.00	110.00	114.76	114.07	57.50	117.50	1.17

Notes: Physical dimensions and tolerances meet the requirements of ASTM Standard D-2467. PVC material meets ASTM Standard D-1784. Dimensions are subject to change without notice. Contact your HYDROSEAL representative for certification.